

THIS DRAWING IS UNPUBLISHED. RELEASED FOR PUBLICATION
 © COPYRIGHT BY TYCO ELECTRONICS CORPORATION. ALL RIGHTS RESERVED.

LOC	DIST	REVISIONS					
HM	00	P	LTR	DESCRIPTION	DATE	DWN	APVD
		V		OBS. 6/3, EC 0502-0843-97	20MAY98	DS	EL
		W		SUPSD -1, REV ECO-07-029245	19MAR08	LH	BM
		Y		REV ECO-08-007212	31MAR08	LH	BM

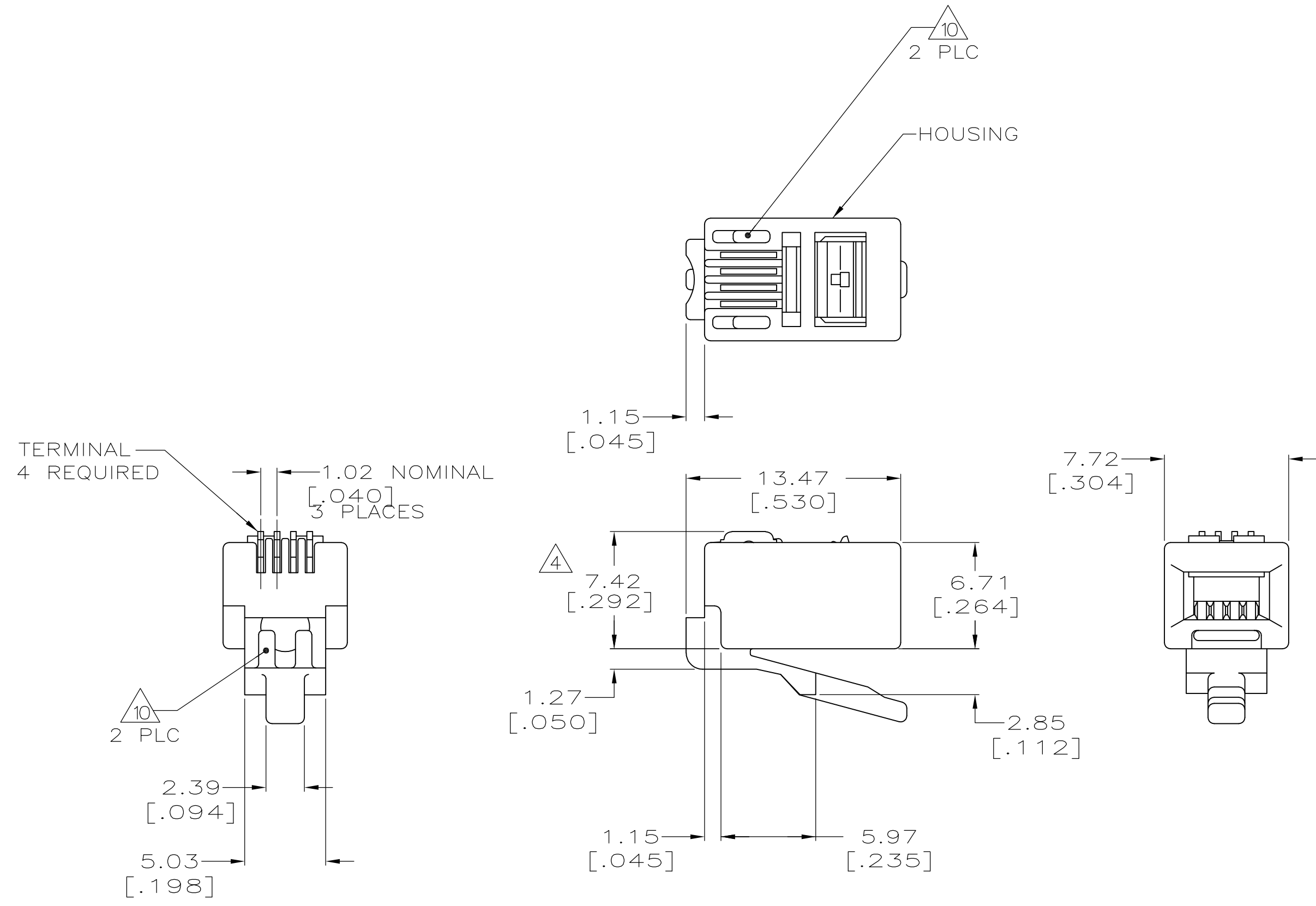

- ① DIMENSIONS ARE MAXIMUM UNLESS OTHERWISE SPECIFIED.
- ② MATERIAL: HOUSING—POLYCARBONATE, CLEAR. TERMINAL—0.36[.014] THICK PHOSPHOR BRONZE PLATED WITH 1.27 μ m[.000050] THICK GOLD IN LOCALIZED GOLD PLATE AREA, GOLD FLASH OVER THE REMAINDER, OVER 2.54 μ m[.000100] THICK NICKEL UNDERPLATE.
- 3. PLUG WILL ACCEPT 26 OR 28 AWG STRANDED WIRE, 0.99[.039] MAX INSULATION DIAMETER, WITH A 2.29 X 4.83 [.090 X .190] OVAL JACKET.
- ④ TERMINATED DIMENSION 6.15[.242] MAXIMUM.
- ⑥ 10,000 ASSEMBLES PER PACKAGE.
- ⑦ 1000 ASSEMBLIES PER PACKAGE.
- ⑧ 100 ASSEMBLIES PER PACKAGE.
- ⑨ 25 ASSEMBLIES PER PACKAGE.

SUPERSEDED BY 5-641334-2

⑨	5-641334-7
⑧	5-641334-3
⑦	5-641334-2
⑥	5-641334-1
REELED ⑩	641334-1
PACKAGED	PART NO.

THIS DRAWING IS A CONTROLLED DOCUMENT.		DWN	8-31-93	Tyco Electronics Corporation	
DIMENSIONS: MM [INCHES]		YTP/UTA	9-15-93	Harrisburg, PA 17105-3608	
TOLERANCES UNLESS OTHERWISE SPECIFIED:		CHK	C.WHITT	NAME	
0 PLC	± -	APVD	-	PRODUCT SPEC	
1 PLC	± -	108-1163		APPLICATION SPEC	
2 PLC	± -	114-6016		SIZE	CAGE CODE
3 PLC	± -	WEIGHT		A2	00779
4 PLC	± -	CUSTOMER DRAWING		DRAWING NO. 641334	
ANGLES	± -	SCALE		SHEET	
FINISH	-	4:1		1 OF 1	
		REV		Y	